

BALL VALVES / Válvulas de bola
SPECIALS / Especiales
FORGED STEEL - 2 PC / Acero forjado - 2 piezas
CLASS / Clase 800
Fig. 5F2P08

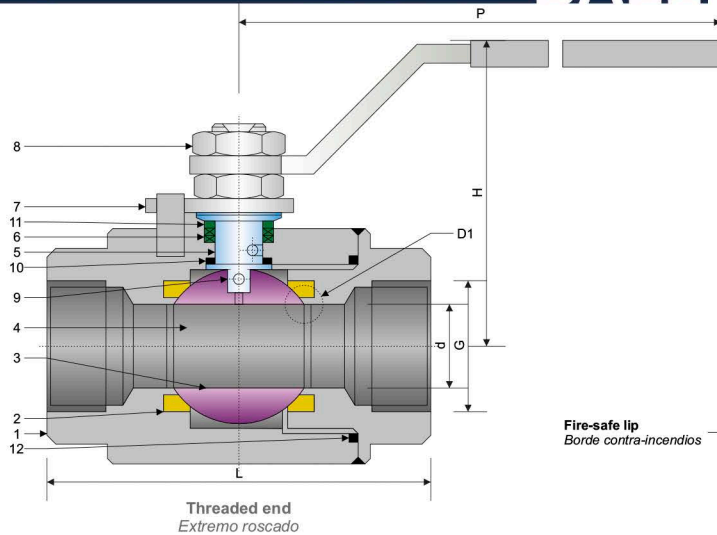

FULL BORE / Paso total

BALL



STRUCTURE FEATURES

Características de la estructura

- **2PC Body**
Cuerpo de 2 piezas
- **Anti-static**
Anti-estático
- **Firesafe**
Contra-incendios

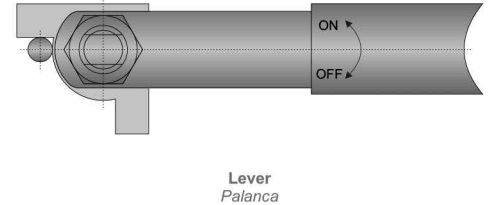
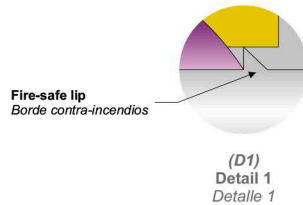

SPECIFICATIONS / Especificaciones

DESIGN <i>Diseño</i>	WORKING PRESSURE <i>Presión de Trabajo</i>	CONNECTION END / <i>Extremos</i>	TEST & CHECK <i>Prueba y Verificación</i>	SIZES <i>Rango</i>
		THREADED <i>Roscados</i>		
BS 535	CLASS 800 (2000 psi)	BSPT, NPT, DIN29999	API 598	1/4" - 2"

MAIN PARTS MATERIAL / Material de las piezas principales

Nº	PART NAME <i>Nombre de pieza</i>	CARBON STEEL <i>Acero al Carbono</i>
1	Body / <i>Cuerpo</i>	A105N - F316
2	Seat ring / <i>Asiento</i>	PTFE
3	Ball / <i>Bola</i>	316
4	Cap / <i>Capuchón</i>	A105N - F316
5	Stem / <i>Vástago</i>	316
6	Packing / <i>Empaquetadura</i>	Graphite / <i>Grafito</i>
7	Lever / <i>Palanca</i>	304
8	Stem nut / <i>Tuerca Vástago</i>	304
9	Anti Static / <i>Antiestático</i>	Stainless Steel 304 / <i>Acero Inoxidable 304</i>
10	Stem Sealing / <i>Sello Vástago</i>	PTFE
11	Gland / <i>Prensaestopa</i>	Stainless Steel 316 / <i>Acero Inoxidable 316</i>
12	Gasket / <i>Junta</i>	Graphite / <i>Grafito</i>

MAIN EXTERNAL DIMENSIONS / Dimensiones externas principales

CLASS 800 (NPS 1/4" - 2")

NPS (in.)	Ød	G	L	H	P
1/4"	6	1/4" - 18 NPT	60	55	120
3/8"	10	3/8" - 18 NPT	60	60	120
1/2"	12.7	1/2" - 14 NPT	75	65	150
3/4"	17.5	3/4" - 14 NPT	80	72	150
1"	22	1" - 11 - 1/2 NPT	90	80	170
1 1/4"	28.5	1 1/4" - 11 - 1/2 NPT	110	80	170
1 1/2"	35	1 1/2" - 11 - 1/2 NPT	120	105	240
2"	47.5	2" - 11 - 1/2 NPT	140	114	240

Notes / Notas:

- **Approximate weights / Pesos aproximados.**
- **Larger diameters on request / Diámetros superiores bajo petición.**
- **Other material on request / Otros materiales bajo petición.**

UNITS / *Unidades mm*